

# Tray labels

Tray labels are used to direct mail from the customer, through processing and delivery, to the end recipient. One label can be used from start to finish.

Correct tray labels are essential to ensure the timely delivery of mail – without them, the mail can't go anywhere fast.

Letters need to be presented in trays for processing and transporting. The correct type of tray depends on the letter category used:

- ❶ For Small and Small Plus letters, use Small Tray labels and Small Letter trays
- ❷ For Medium and Large letters, use Large Tray labels and Large Letter trays.

Once the appropriate tray size has been selected, the correct label needs to be affixed to the tray.

Tray labels identify the final destination and contents of each tray. Different labels are needed for different products and tray sizes.

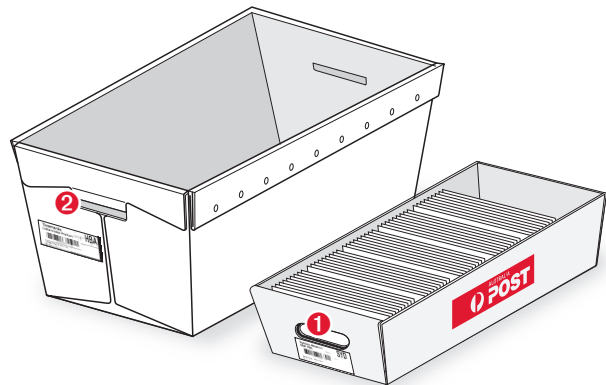

## Features of a tray label

A lot of information is contained on mail tray labels and in their barcodes. This information is crucial to ensure bulk mail gets to its correct destination.

### Destination state

### Sort plan

Barcode, Print Post or Impact Mail

### Product

PreSort Letters, Unaddressed Mail, Clean Mail, Print Post or Impact Mail

### Selected service type

e.g. Off-Peak or Regular PreSort Letters

### Mail centre

### Tray type

Whether it is a Large or Small letter tray

### Mailer details

Mailers job reference number

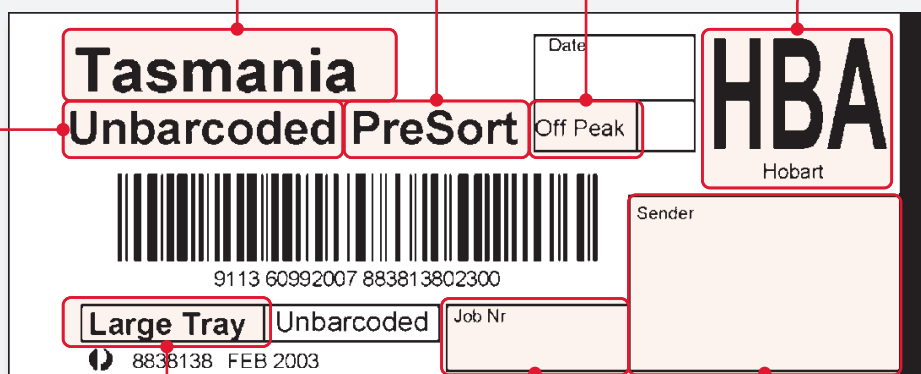

# Fact Sheet – Tray labels

## Label options

There are two label options:

### ► Pre-printed labels

Identical preprinted labels, with spaces for manual entry of customer and lodgement details. They are available for customers who prefer not to print their own labels. Australia Post provides preprinted tray labels at no cost.

### ► Print on Demand labels

Typically used by bulk mail customers printing their own labels.

Australia Post offers tray labelling software (TLMS (VISA) Labelling Software) to bulk mail customers at no cost.

Software order forms and platform requirements can be found on Australia Post's website at [www.auspost.com.au/traylabels](http://www.auspost.com.au/traylabels), or by contacting the Technical Support Centre on **1800 000 242**. Customers may also purchase third party software to generate tray labels. These labels must conform to specifications, which are subject to periodic review. Specifications may be obtained by contacting the Technical Support Centre or by downloading documentation from Australia Post's website. Third party software must be approved by Australia Post prior to use.

Blank label stock is also provided free of charge by Australia Post. The labels stock has a special layer of heat sensitive material to print labels with superior contrast for clearer barcodes and text. It is suitable for use only in direct thermal label printers.

## Sort Plans and tray label updates

Every six months in March and September, Australia Post updates Sort Plans due to changes in destinations, postcodes, and products. Visa Tray label software is also updated to coincide with these Sort Plan changes, to ensure labels produced match Sort Plan details.

Customers should ensure that all labels preprinted in advance from a previous version of a Sort Plan are destroyed. This ensures obsolete versions are not accidentally used in mail preparation.

If obsolete labels are used there is a likelihood of mail being directed to the wrong location, therefore causing delivery delays.

## More Information

Additional information can be accessed in the Mail Label Specifications booklet available at the Australia Post website [www.auspost.com.au/traylabels](http://www.auspost.com.au/traylabels)

## Preparing labels

The following basic rules apply when preparing tray labels...

**Observe maximum tray weights:** The maximum acceptable weight of a tray, including its contents, is 16kg. This is to comply with OH&S requirements.

**Use the correct label:** If customers use the wrong label their mail may be directed to the wrong destination. For instance, when the contents of the tray is for 'WA' but a 'NSW' label is used mail will be directed to NSW, causing delivery delays.

**Do not amend a label:** No pen amendments are recognised by the Tray Management System (TMS). Therefore, amended labels may impact the readability of the label by machinery, or be sent to the wrong processing area, potentially causing delivery delays.

**Use clean trays:** Tray hygiene means ensuring that letter trays are clean, free of old labels and are in good working order. Tray hygiene is important because there is a risk that old labels on trays may result in mail being mis-sorted to the wrong destination, potentially causing delivery delays.

**Tray label compliance:** It is important that labels generated by customers are compliant to published standards. If labels are non-compliant the result can be that the TMS is unable to read the tray label barcode, resulting in processing delays.

## Basic labelling rules

### Do's

- ✓ Use correct label product (service) size and category
- ✓ Use the current version of labels
- ✓ For Visa Print on Demand customers the current version can be verified via email to [visalabels@auspost.com.au](mailto:visalabels@auspost.com.au)  
Correct version of Pre-printed labels will be supplied from the warehouse.

### Don'ts

- ✗ Amend labels by writing on them with pen/pencil/whiteout
- ✗ Photocopy labels
- ✗ Stamp over the barcode on tray labels
- ✗ Just use any label – use the one appropriate for the service and the letter size category
- ✗ Apply wrong category or size to incorrect tray.